

Instruction Manual

Pearl Swivel Joint

SRK/SSH Series

This instruction manual applies to products with type designations that begin with SRK or SSH. (This manual does not apply to movable pipelines or products that include flanges for connection, or which require welding.)

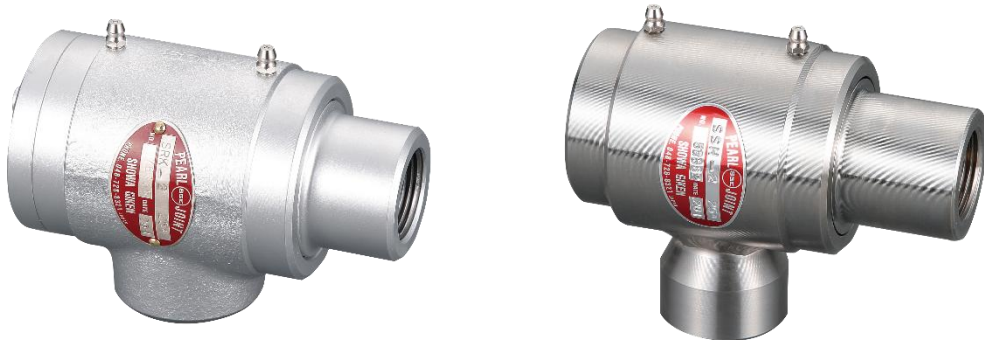

This instruction manual describes important precautions for preventing accidents and how to handle the product. To ensure safe use, be sure to read this manual and fully understand its contents before using this product. Store this manual carefully so that it can be referred to at any time.

Pearl is a trade name of Showa Giken Industrial Co., Ltd.

Table of Contents

1. How to Read Nameplate (Nameplate Information)	P3
2. For Safety	P3
2-1) Symbols	P3
2-2) For safe use	P3
3. Product Overview	P4
3-1) Application	P4
3-2) Information indicated by model names	P4
3-3) Service conditions	P4
3-4) Precautions for use	P5
3-5) Product structures and materials	P6
3-6) Product dimensions	P7
3-7) Product masses	P7
3-8) Product torque	P7
4. Transport and Storage	P8
4-1) Transport	P8
4-2) Storage	P8
5. Installation	P8
6. Removal	P9
7. Operation	P9
7-1) Operation	P9
7-2) Operation shutdown	P9
8. Inspection and Maintenance	P10
8-1) Daily inspection	P10
8-2) Greasing	P10
8-3) Repair and replacement of consumables	P11
9. Troubleshooting	P12
10. Disposal	P13
11. Product Warranty	P13
A. Appendix – How to Repair or Replace Consumables	P15
A-1) SRK Series	P16
A-2) SSH Series (10A, 15A)	P18
A-3) SSH Series (20A~40A)	P20

1. How to Read Nameplate (Nameplate Information)

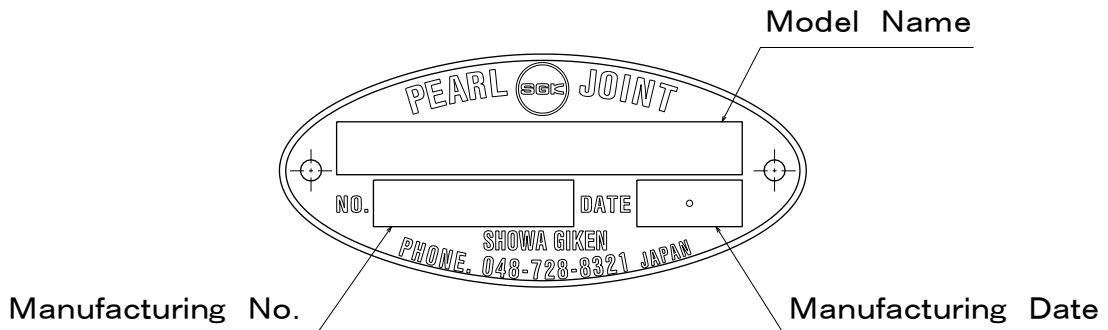

The nameplate attached to the product indicates the model name, manufacturing number, and manufacturing date.

2. For Safety

2-1) Symbols

The symbols used in this instruction manual are described below.



Indicates that failure to follow the warning message may cause bodily accidents that may result in serious or even fatal injury.



Indicates that failure to follow the caution message may cause personal injury or damage to peripheral equipment.



Indicates that failure to follow the instruction message may cause reduced product lifetime, product damage, or early leakage.



Indicates “prohibited actions”.

2-2) For safe use

1. Transport, storage, installation, piping, operation, or maintenance of this product should be carried out by an experienced expert.
2. Be sure to observe all warnings, cautions, and instructions described in each section.
3.  Never disassemble or modify this product because doing so is dangerous. We shall assume no responsibility for any malfunctions, accidents, or the results thereof involving a reassembled product after disassembly or a modified product. Also, a reassembled product after disassembly or a modified product shall not be covered by the product warranty even if the warranty period is still valid. This also applies to repairs done by yourself.
4. Confirm specifications (dimensions, materials, masses) indicated on individual product drawings before starting work. Contact our sales representative for requests for product drawings.
5. Always use the latest instruction manual. You can download the latest version from our website.

3. Product Overview

3-1) Application

A swivel joint is used when it is necessary to rotate a pipe for transporting fluid or move it up/down, left/right, or forward/backward.

3-2) Information indicated by model names

Information indicated by each series model names is described below.
The product list is shown in our catalog or on our website.

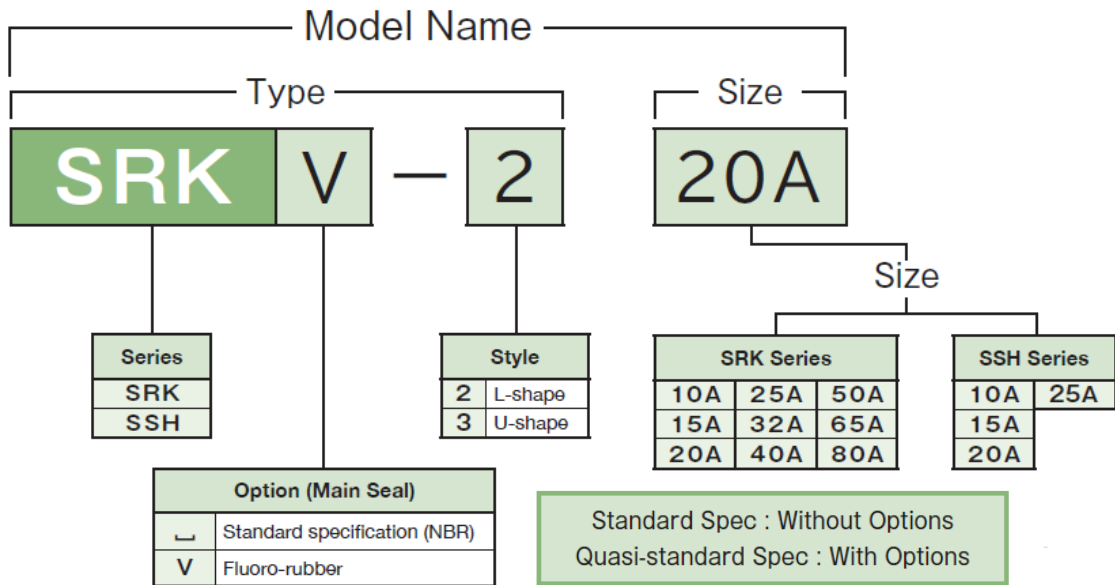

Note) “_” indicates a space. A model name is indicated without spaces.

If you have any questions, contact our sales representative.

3-3) Service conditions

Service Conditions of Each Series

Series	Connection	Material (main parts)	Main Seal	Style	Size	Max.	
						Pressure (MPa)	Temperature (°C)
SRK	Taper Thread (Rc)	Carbon Steel	O-ring NBR	2, 3	10A~40A	34.3	100
					50A~65A	24.5	
				2	80A	24.5	
SSH	Taper Thread (Rc)	Stainless Steel	O-ring NBR	2	10A~25A	20.6	100

Note) The main seal for the standard specification of each series is an O-ring (NBR).

3-4) Precautions for use

Use this product by following the warnings and instructions described below.





WARNING

1. If flammable fluids leak and ignite, bodily accidents including serious or even fatal injury, or accidents that damage peripheral equipment may occur due to explosion or fire. Depending on the type of fluid, this product may be subject to restrictions due to national laws or local regulations.
2.  This product cannot be used for food-processing machinery. Doing so may lead to adverse health effects.



Instruction

1. Perform operation within the service conditions.
2.  The standard specification main seal (NBR) cannot be used for phosphoric ester-based hydraulic oil, chlorinated hydrocarbon-based hydraulic oil, organic solvents, or acids.
3.  The product cannot be used for fluid that causes corrosion on it.
4. As an elastic seal is used, use of the product in consecutive rotation condition is not appropriate. The product lifetime becomes shortened.
5. Two radial ball bearings are incorporated in a product and there is no clearance (play). Shaft movement is restricted in the swivel direction. When introducing a hose for connecting the product or a movable pipeline for using multiple products, carefully consider the motion of the hose and the movable pipeline before selecting a style.

3-5) Product structures and materials

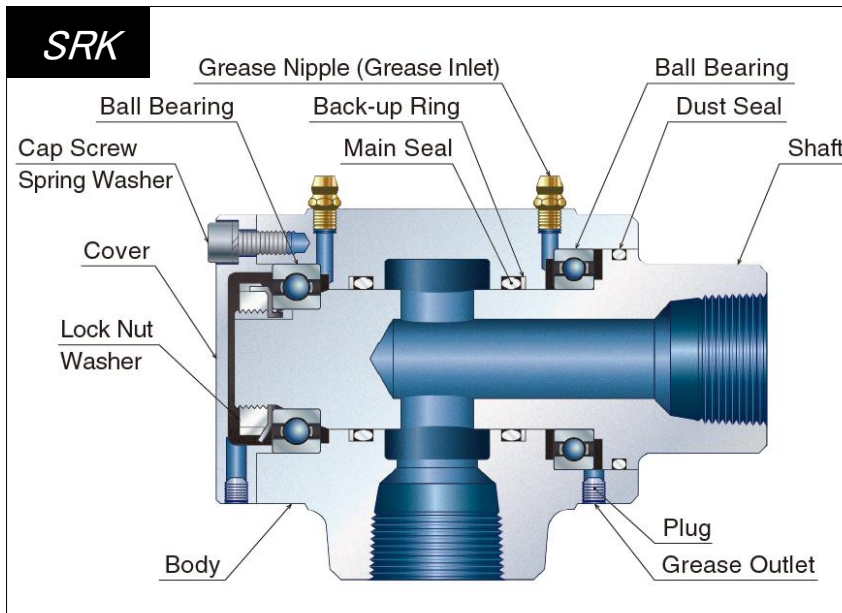

Materials of Main Components (Standard Specification)

Part Name	Material
Shaft	Carbon Steel
Body	
Main Seal	NBR
Back-up Ring	PTFE

Heat-resistant paint is applied to external parts.

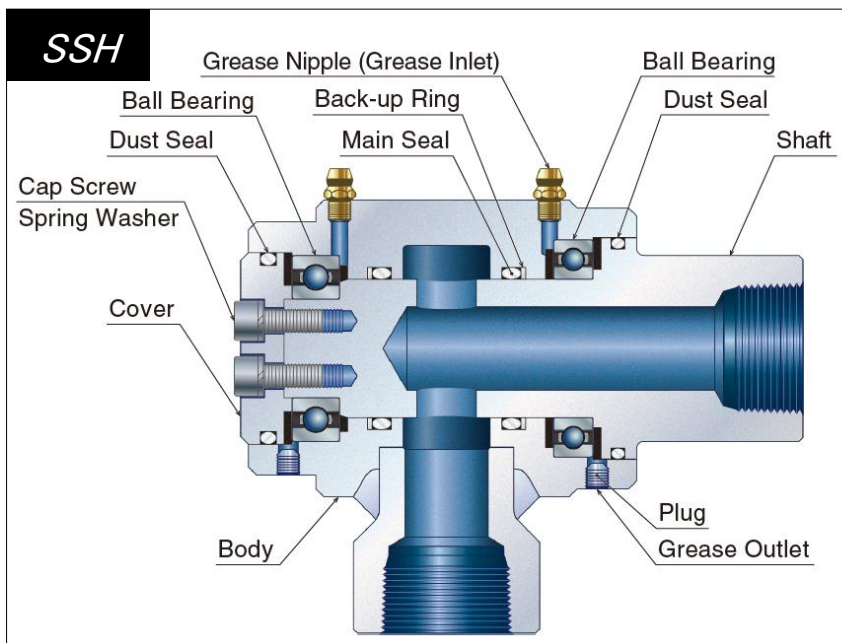

Materials of Main Components (Standard Specification)

Part Name	Material
Shaft	Stainless Steel
Body	
Main Seal	NBR
Back-up Ring	PTFE

* 10A and 15A are not grease-type products. Ball bearings are grease-sealed type products without a grease nipple and a plug.

Note) Component materials are indicated on product drawings.
Contact our sales representative for requests for product drawings.

3-6) Product dimensions

Product dimensions are shown on product drawings, in our catalog, or on our website.

3-7) Product masses

Masses of SRK Series (kg)

Size	Style	
	2	3
10A	1.6	1.7
15A	1.6	1.7
20A	3.7	3.9
25A	3.8	4.1
32A	7.0	7.6
40A	7.3	8.0
50A	12.6	13.6
65A	23.0	24.8
80A	28.0	–

Masses of SSH Series (kg)

Size	Style
	2
10A	1.4
15A	1.4
20A	3.4
25A	3.4

3-8) Product torque

- * Dynamic torque varies depending on product storage conditions, storage period, or fluid types.
- * Starting torque is larger than dynamic torque. Although starting torque is even larger when wringing occurs, it does not indicate any fault.
- * Data are typical values measured based on in-house test standards. They are not guaranteed values.

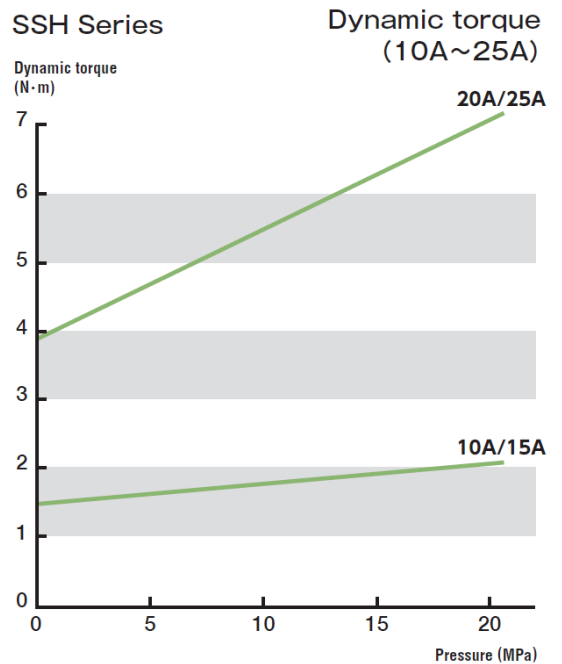
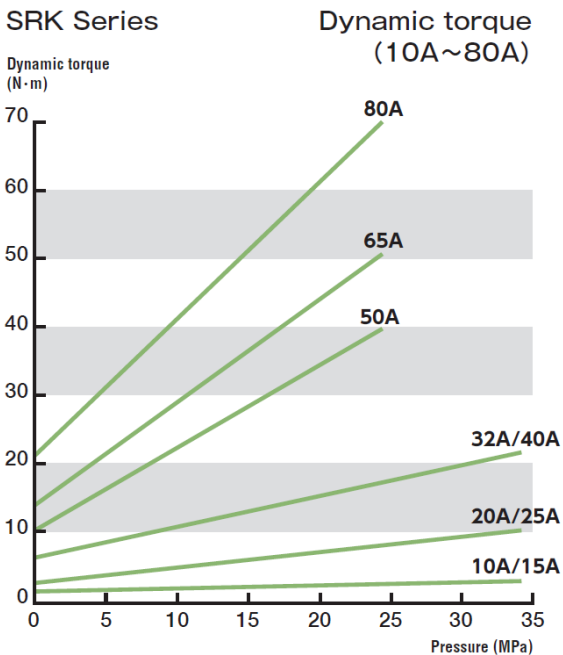

4. Transport and Storage

4-1) Transport

Transport this product by following the cautions and instructions described below.



CAUTION

To transport a product that weighs over 25 kg, use appropriate lifting equipment to prevent injuries.



Instruction

Do not subject the product to undue impact while it is being transported. Falling down or impact causes product damage (grease nipple etc.) or early leakage. If the product fell down or was damaged, contact us for maintenance.

4-2) Storage

An improper storage method causes product damage or early leakage.

Store this product by following the instructions described below.



Instruction

1. Wrap the product before storing it to prevent the entry of foreign objects.
2. Store this product in a dry environment at 10°C to 40°C.
3. The storage period should be within two years. If the storage period exceeds two years, contact us for maintenance.
4. If the product is stored after use, clean and then store it under the above conditions.

5. Installation

Product adjustment is not required before installation.

Install the product by following the cautions and instructions described below.



CAUTION

In order to prevent injuries, take the product weight into consideration before installing the product. Use equipment such as a crane as necessary. This work should be performed by two or more persons.



Instruction

1. **Thoroughly flush flow passages to remove foreign objects** before product installation. If the fluid contains foreign objects, install a strainer at the flow passages. Foreign objects cause early leakage.
2.  **Avoid pipe laying where excessive moment load is applied to the product.** Failure to do so can cause early leakage.
3. When tightening screws or nuts, properly torque-tighten them according to the screw type or size.
4. Perform retightening after the start of use.

6. Removal

Perform removal by following the warnings and cautions described below.



In order to prevent bodily accidents due to residual fluid in the product or pipes, remove the product after fluid has been completely drained from the product or pipes and temperature has dropped to room temperature.



In order to prevent injuries, take the product weight into consideration before removing the product. Use equipment such as a crane as necessary. This work should be performed by two or more persons.

7. Operation

7-1) Operation

Perform operation by following the warnings and cautions described below.



Immediately stop operation if fluid leakage is detected during operation. If operation is continued with fluid leakage not being repaired, serious accidents including bodily accidents may result.



 During rotation or high-temperature/pressure fluid flow, keep well away from the product to prevent injuries or burns. Do not directly touch rotating or hot parts during operation.

7-2) Operation shutdown

Follow the following instructions during operation shutdown.



 Do not put your hand on or ride on the product during equipment maintenance. Doing so may cause product damage or fluid leakage after operation restart.

8. Inspection and Maintenance

8-1) Daily inspection



Perform inspection according to the following instructions.

 Instruction	<ol style="list-style-type: none"> 1. Visually check connections and the product for fluid leakage. If leakage is detected, repair the product or replace it with a new one. 2. When replacing, use the same type of product with the same size.
---	--

8-2) Greasing

The ball bearings and the main seal require periodic greasing (refilling).
(Except for 10A and 15A of the SSH series)

Carry out greasing according to the following instructions.

 Instruction	<ol style="list-style-type: none"> 1. Remove the grease outlet plug and fill the grease through the grease nipple (grease inlet). Continue to fill until new grease comes out from the grease outlet. 2. <u>If the grease is filled without removing the plug, parts inside the product may be damaged by the grease pressure, causing fluid leakage.</u> 3.  Use the same grease as the one filled in the product before shipment. Do not use grease mixed with other ones. Doing so may reduce the lubricating effect. 4. Carry out greasing with reference to the frequency and amount (guideline) shown in the following table. Failure to carry out greasing can reduce the lubricating performance of the grease, causing the reduction in the ball bearing lifetime.
---	---

< Grease filled in the product before shipment >

Gasus S2 V125J 1(Shell Lubricants Japan K.K.) is filled in the SRK/SSH series.

Greasing Frequency (Guideline)

Fluid Temperature (°C)	Greasing Frequency
0~60	Yearly
60~100	Every six months

SRK Series
Grease Amount (Guideline) (cm³)

Size	Cover side		Shaft side	
	First Time	Refill	First Time	Refill
10A	5	2.5~3.0	3	1.5~1.8
15A				
20A	7	3.5~4.2	5	2.5~3.0
25A				
32A	14	7.0~8.4	9	4.5~5.4
40A				
50A	35	18~21	13	6.5~7.8
65A	42	21~25	27	14~16
80A	49	25~29	36	18~22

SSH Series
Grease Amount (Guideline) (cm³)

Size	Cover side		Shaft side	
	First Time	Refill	First Time	Refill
10A	-	-	-	-
15A	-	-	-	-
20A	5	2.5~3.0	5	2.5~3.0
25A				

8-3) Repair and replacement of consumables

The ball bearings and main seal become worn over the course of operation time. Moreover, the main seal deteriorates and then such malfunctions as fluid leakage may occur. However, the product can be reused by repairing or replacing worn or deteriorated parts.

Contact us for repair or parts replacement. We carry it out according to our repair program. Depending on the products, expenses for purchasing new products may be lower than repair expenses. Consult with us when requesting repair or replacement.

< When carrying out repair or replacement of consumables by yourself >

- Repair or replacement should be carried out by an experienced expert.
- Perform work according to “A. Appendix – How to Repair or Replace Consumables”.
- Use our genuine parts as replacement parts.
Contact our sales representative to request genuine parts.
- Properly dispose of waste resulting from work according to national laws or local government regulations or ordinances.

(Attention)

If you carry out repair or replacement, we shall assume no responsibility for any product malfunctions, equipment malfunctions or accidents resulting from such product or the results thereof. Also, the product shall not be covered by the product warranty even if the warranty period is still valid.

9. Troubleshooting

This section describes the possible causes of and countermeasures against malfunctions. If a problem persists, contact our sales representative for assistance.

Malfunctions	Causes	Countermeasures
Fluid is leaking.	The main seal is damaged. The main seal lifetime has been reached.	Contact us for repair. Alternatively, replace with a new one.
	The fluid contains foreign objects.	Clean the inside of the product and pipes. Install a strainer.
	Excessive moment acts on pipes, etc.	Review the pipe laying method.
	An improper main seal material was selected.	Consult with us.
The shaft does not rotate. (Starting torque is high.)	A ball bearing does not rotate.	Contact us for repair.
	The seal causes wringing.	Rotate the shaft a few turns to check that it rotates smoothly before use.
	Sticking of fluid (that has ability to solidify).	After using the product, clean its inside to remove foreign objects.
Lifetime is shortened.	The product is used in consecutive rotation condition or at high-rotation speed.	Consult with us. (The selected product may be inappropriate.)

10. Disposal

When disposing of packaging materials or products, properly dispose of them according to national laws or local government regulations or ordinances.

11. Product Warranty

If a malfunction occurs during the warranty period, contact us or the distributor and send the product to us. Be sure to carefully pack the product for protection before sending it. After receiving the product, we will confirm the malfunction. If the malfunction was clearly caused by the materials of product components or the manufacturing method, we will repair the product in question or replace it with a new one free of charge.

Product Warranty Provision

1. Warranty period

<New products>

One (1) year and six (6) months after shipment (from the manufacturing date) or one (1) year after installation, whichever comes first.

<Repaired products>

Six (6) months after shipment (from the manufacturing date).

2. We charge a fee for repairs in any of the following cases.

- ① Failure after the warranty period has expired
- ② Failure caused by use of the product deviating from the service conditions
- ③ Failure caused by misuse
(improper storage, installation, pipe laying, operation or maintenance, etc.)
- ④ Failure caused by fluid contaminants or foreign objects in the fluid
- ⑤ Failure caused by relocation, transport, or falling of the product after delivery
- ⑥ Failure caused by disassembly, repair, or modification done by personnel other than our service personnel
- ⑦ Failure of the product attributed to using materials or according to standards specified by the customer
- ⑧ Failure of the product attributed to using materials provided by the customer
- ⑨ Failure caused due to unavoidable acts of nature such as fires or other natural disasters

3. Scope of responsibility

Our responsibility shall be limited to repairs, replacements, or transport expenses covered by this product warranty provision. Expenses or damages caused by said failures above shall not be covered.

4. Applicable regions

This product warranty provision shall be applicable to products installed in Japan.
Contact our sales representative if you install and use our products outside Japan.

5. Another agreement

If another product warranty agreement is made separately with us and clearly states that said agreement shall have priority over this product warranty provision, this provision shall not be applicable.

6. This product warranty provision shall not restrict the customer's legal rights.

PEARL  **JOINT**
株式会社 昭和技研工業
SHOWA GIKEN INDUSTRIAL CO., LTD.

URL <https://www.sgk-p.co.jp>



Export Department Phone : +81-3-3598-1400 Fax. : +81-3-3598-2700
E-mail : sgk-tk@sgk-p.co.jp
Headquarters 7-24, Nishi-Kobari, Ina-Machi, Saitama, 362-0811 Japan
Phone : +81-48-728-9460 Fax. : +81-48-728-9461
Tokyo Sales Office 2-64-11, Akabane, Kita-ku, Tokyo, 115-0045 Japan
Phone : +81-3-3598-1400 Fax. : +81-3-3598-2700
Osaka Sales Office 2-9-7, Toyosaki, Kita-ku, Osaka, 531-0072 Japan
Phone : +81-6-6371-8341 Fax. +81-6-6371-6283
Nagoya Sales Office 41-1, Higashi-Ozone-cho, Higashi-ku, Nagoya, 461-0022 Japan
Phone : +81-52-938-8825 Fax. : +81-52-938-6423

A. Appendix – How to Repair or Replace Consumables

A-1) SRK Series

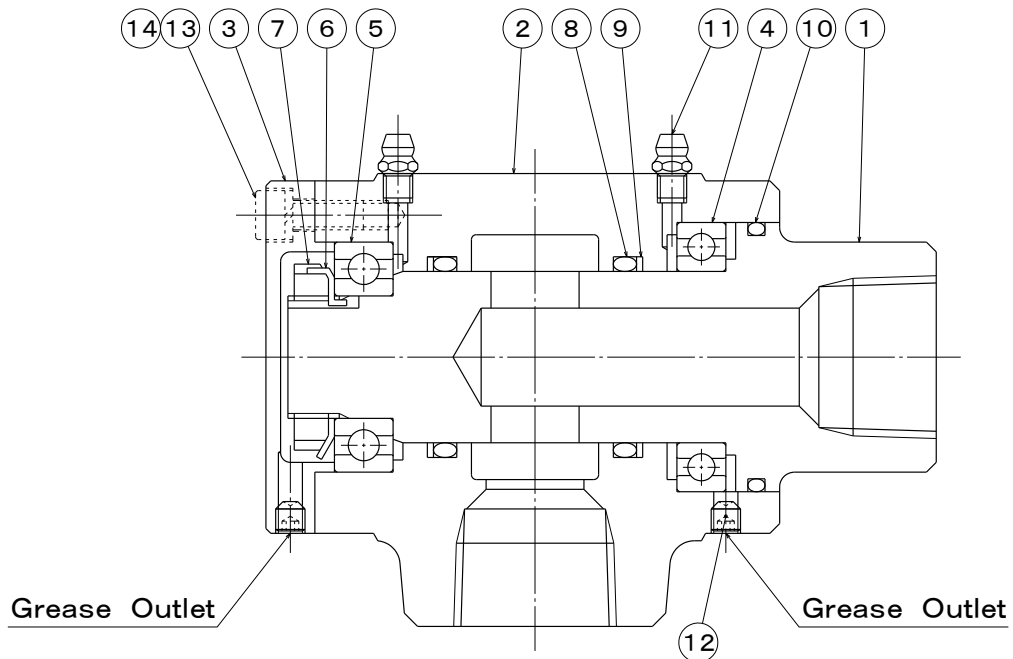

- ①Shaft ②Body ③Cover ④Ball Bearing ⑤Ball Bearing
⑥Washer ⑦Lock Nut ⑧Main Seal ⑨Back-up Ring ⑩Dust Seal
⑪Grease Nipple ⑫Plug (Set Screw) ⑬Cap Screw ⑭Spring Washer

< Disassembly >

Carefully disassemble the product so that each part is not damaged.

- 1) Remove grease nipples ⑪ and plugs (set screws) ⑫.
- 2) Remove cap screws ⑬, and then remove cover ③ from body ②.
- 3) Raise a tab of washer ⑥, and then remove lock nut ⑦ and washer ⑥.
- 4) Clamp body ② with a vice, etc. and pull out shaft ① from body ②. Remove ball bearing ④ from shaft ①.
- 5) Remove ball bearing ⑤ from body ②.
- 6) Remove main seals ⑧ and back-up rings ⑨ from body ②, and then remove dust seal ⑩ from shaft ①.

< Inspection >

Clean each part and check for damage.

- 1) Shaft ①
Check wear and damage conditions of the sliding surfaces against main seals ⑧. Moreover, check the installation faces of ball bearings ④ and ⑤ in the same manner.
- 2) Body ②
Check wear and damage conditions of the sliding surface against dust seal ⑩. Moreover, check the installation faces of ball bearings ④ and ⑤ in the same manner.
- 3) Ball Bearings ④ and ⑤
Check for such damage as rotation failure, corrosion, cracks, and chipping.

< Parts replacement >

- 1) Replace main seals ⑧, back-up rings ⑨, and dust seal ⑩ with new ones regardless of their conditions.
- 2) If reuse of parts is impossible, replace them with our new genuine parts.
Contact our sales representative to request genuine parts.

< Assembly >

Carefully assemble the product so that each part is not damaged. Moreover, install the O-ring so that it is not distorted.

- 1) Install ball bearing ④ to shaft ①.
- 2) Apply grease to dust seal ⑩, and then install it into the groove of shaft ①.
- 3) Apply grease to main seals ⑧ and back-up rings ⑨, and then install them into the grooves of body ②.
- 4) Apply grease to the outer perimeter of shaft ① that slides against main seals ⑧, and the inner perimeter of body ② that slides against dust seal ⑩.
- 5) Insert shaft ① into body ②.
- 6) Install ball bearing ⑤.
- 7) Install washer ⑥ and lock nut ⑦ to shaft ①, and then bend the tab of washer ⑥ to prevent looseness.
- 8) Install cover ③ to body ②, and secure it with cap screws ⑬ and spring washers ⑭. At this point, install so that the grease outlet of body ② and that of cover ③ face in the same direction.
- 9) Turn shaft ① a few turns clockwise/counterclockwise to make sure there is no fault.
- 10) Install grease nipples ⑪ and fill the grease through them. Continue to fill until new grease comes out from the grease outlet.
- 11) After greasing, attach plugs (set screws) ⑬.

A-2) SSH Series (10A, 15A)

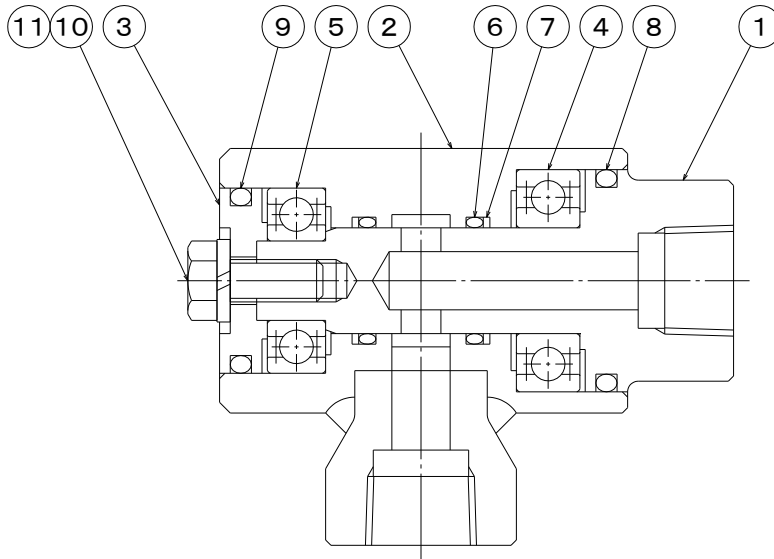

- ①Shaft ②Body ③Cover ④Ball Bearing ⑤Ball Bearing ⑥Main Seal
⑦Back-up Ring ⑧Dust Seal ⑨Dust Seal ⑩Hex. Bolt ⑪Spring Washer

< Disassembly >

Carefully disassemble the product so that each part is not damaged.

- 1) Clamp shaft ① with a vice, etc. and then remove hex. bolt ⑩.
- 2) Pull out body ② from shaft ①. Then remove cover ③ from body ②.
- 3) Remove ball bearing ④ from shaft ①.
- 4) Remove ball bearing ⑤ from body ②.
- 5) Remove main seals ⑥ and back-up rings ⑦ from body ②, dust seal ⑧ from shaft ①, and dust seal ⑨ from cover ③.

< Inspection >

Clean each part and check for damage.

- 1) Shaft ①
Check wear and damage conditions of the sliding surfaces against main seals ⑥. Moreover, check the installation faces of ball bearings ④ and ⑤ in the same manner.
- 2) Body ②
Check wear and damage conditions of the sliding surfaces against dust seals ⑧ and ⑨. Moreover, check the installation faces of ball bearings ④ and ⑤ in the same manner.
- 3) Ball Bearings ④ and ⑤
Check for such damage as rotation failure, corrosion, cracks, and chipping.

< Parts replacement >

- 1) Replace main seals ⑥, back-up rings ⑦, and dust seals ⑧ and ⑨ with new ones regardless of their conditions.
- 2) If reuse of parts is impossible, replace them with our new genuine parts.
Contact our sales representative to request genuine parts.

< Assembly >

Carefully assemble the product so that each part is not damaged. Moreover, install the O-ring so that it is not distorted.

- 1) Install ball bearing ④ to shaft ①.
- 2) Apply grease to dust seal ⑩, and then install it into the groove of shaft ①.
- 3) Apply grease to main seals ⑥ and back-up rings ⑦, and then install them into the grooves of body ②.
- 4) Apply grease to the outer perimeter of shaft ① that slides against main seals ⑥, and the inner perimeter of body ② that slides against dust seals ⑧ and ⑨.
- 5) Insert shaft ① into body ②.
- 6) Install ball bearing ⑤.
- 7) Apply grease to dust seal ⑨, and then install it into the groove of cover ③.
- 8) Install cover ③ to shaft ①, and then secure it with hex. bolt ⑩ and spring washer ⑪.
- 9) Turn shaft ① a few turns clockwise/counterclockwise to make sure there is no fault.

A-3) SSH Series (20A~40A)

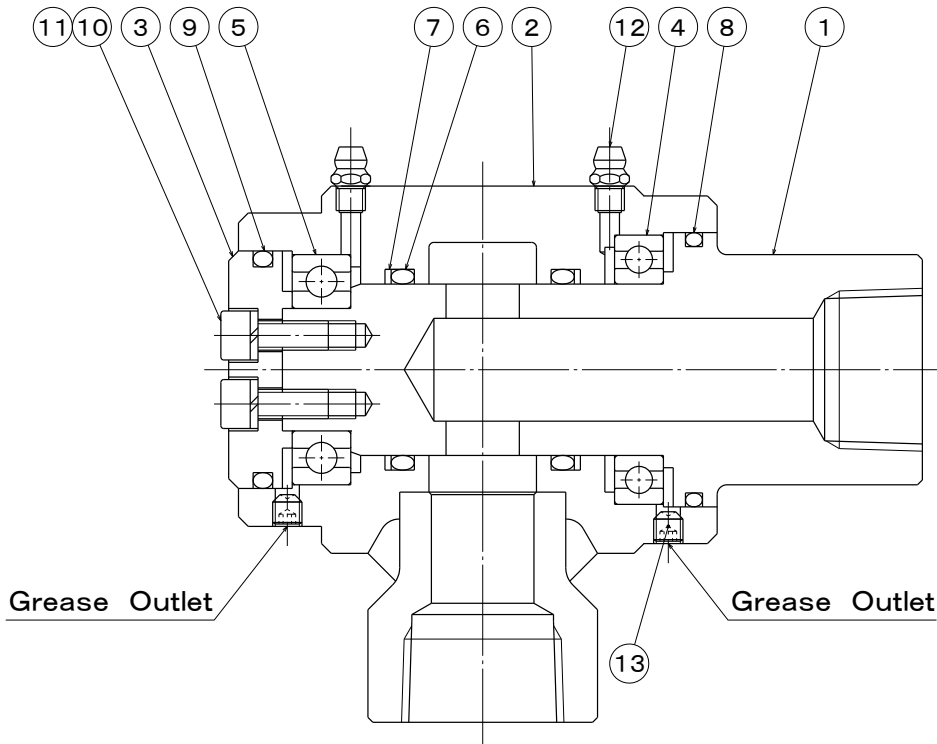

- ①Shaft ②Body ③Cover ④Ball Bearing ⑤Ball Bearing ⑥Main Seal
⑦Back-up Ring ⑧Dust Seal ⑨Dust Seal ⑩Cap Screw ⑪Spring Washer
⑫Grease Nipple ⑬Plug (Set Screw)

< Disassembly >

Carefully disassemble the product so that each part is not damaged.

- 1) Remove grease nipples ⑫ and plugs (set screws) ⑬.
- 2) Clamp shaft ① with a vice, etc. and then remove hex. bolts ⑩.
- 3) Pull out body ② from shaft ①. Then remove cover ③ from body ②.
- 4) Remove ball bearing ④ from shaft ①.
- 5) Remove ball bearing ⑤ from body ②.
- 6) Remove main seals ⑥ and back-up rings ⑦ from body ②, dust seal ⑧ from shaft ①, and dust seal ⑨ from cover ③.

< Inspection >

Clean each part and check for damage.

- 1) Shaft ①
Check wear and damage conditions of the sliding surfaces against main seals ⑥. Moreover, check the installation faces of ball bearings ④ and ⑤ in the same manner.
- 2) Body ②
Check wear and damage conditions of the sliding surfaces against dust seals ⑧ and ⑨. Moreover, check the installation faces of ball bearings ④ and ⑤ in the same manner.
- 3) Ball Bearings ④ and ⑤
Check for such damage as rotation failure, corrosion, cracks, and chipping.

< Parts replacement >

- 1) Replace main seals ⑥, back-up rings ⑦, and dust seals ⑧ and ⑨ with new ones regardless of their conditions.
- 2) If reuse of parts is impossible, replace them with our new genuine parts.
Contact our sales representative to request genuine parts.

< Assembly >

Carefully assemble the product so that each part is not damaged. Moreover, install the O-ring so that it is not distorted.

- 1) Install ball bearing ④ to shaft ①.
- 2) Apply grease to dust seal ⑧, and then install it into the groove of shaft ①.
- 3) Apply grease to main seals ⑥ and back-up rings ⑦, and then install them into the grooves of body ②.
- 4) Apply grease to the outer perimeter of shaft ① that slides against main seals ⑥, and the inner perimeter of body ② that slides against dust seals ⑧ and ⑨.
- 5) Insert shaft ① into body ②.
- 6) Install ball bearing ⑤.
- 7) Apply grease to dust seal ⑨, and then install it into the groove of cover ③.
- 8) Install cover ③ to shaft ①, and then secure it with cap screws ⑩ and spring washers ⑪.
- 9) Turn shaft ① a few turns clockwise/counterclockwise to make sure there is no fault.
- 10) Install grease nipples ⑫ and fill the grease through them. Continue to fill until new grease comes out from the grease outlet.
- 11) After greasing, attach plugs (set screws) ⑬.